

SHOULDER MILLING – NAVIGATOR

SHOULDER MILLING – NEGATIVE INSERTS

	STN10		STN16		SLN12		SLN16		SLN12X											
	90°		90°		90°		90°		90°											
	APMX (mm)	5.0	APMX (mm)	10.0	APMX (mm)	9.0	APMX (mm)	13.0	APMX (mm)	10.0										
	DC (mm)	18 – 80	DC (mm)	25 – 175	DC (mm)	25 – 125	DC (mm)	63 – 175	DC (mm)	25 – 125										
Cylindrical shank		DC = 18 – 35 (mm)		DC = 25 – 35 (mm)		DC = 25, 32 (mm)				DC = 25 – 40 (mm)										
Weldon		DC = 20 – 32 (mm)		DC = 25 – 40 (mm)		DC = 25 – 40 (mm)				DC = 25 – 40 (mm)										
Modular		DC = 20 – 32 (mm)		DC = 25 – 40 (mm)		DC = 25 – 40 (mm)														
Shell mill		DC = 40 – 80 (mm)		DC = 40 – 175 (mm)		DC = 40 – 125 (mm)				DC = 40 – 125 (mm)										
Page	66		70		75		81		85											
ISO	P	M	K	N	P	M	K	N	P	M	K	N	P	K	N	H	P	M	K	H
Insert shape																				
Inserts	TNGX 1004		TNGX 1606		LNG. 1205		LN.U 1607		LNEX 1210											
No. of cutting edges	6		6		4		4		4											
Shallow shoulder milling	■		■		■		■		■											
Helical interpolation	▣		▣		▣		▣		▣											
Shallow slot milling	■		■		■		■		■											
Plunge milling	▣		■		■		■		■											
Progressive plunging	▣		■		▣		■		■											
Ramping	▣		■		▣		■		▣											
Face milling	■		■		▣		■		■											
Shape surfaces milling (copy milling)	■		■		▣		▣		■											

STN10

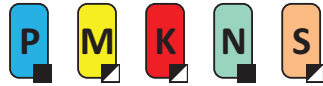

PRAMET

S



ECON TN10 Square Shoulder Mill with Internal Coolant

90° end and shell mills utilizing double sided TNGX 10 insert with 6 cutting edges and APMX of 5 mm. Suitable for a wide range of applications. Available in cylindrical, Weldon, modular and arbor style, with or without differential tooth pitch. Body treated for longer tool life.

ECON TN

KAPR	90°
APMX	5.0 mm

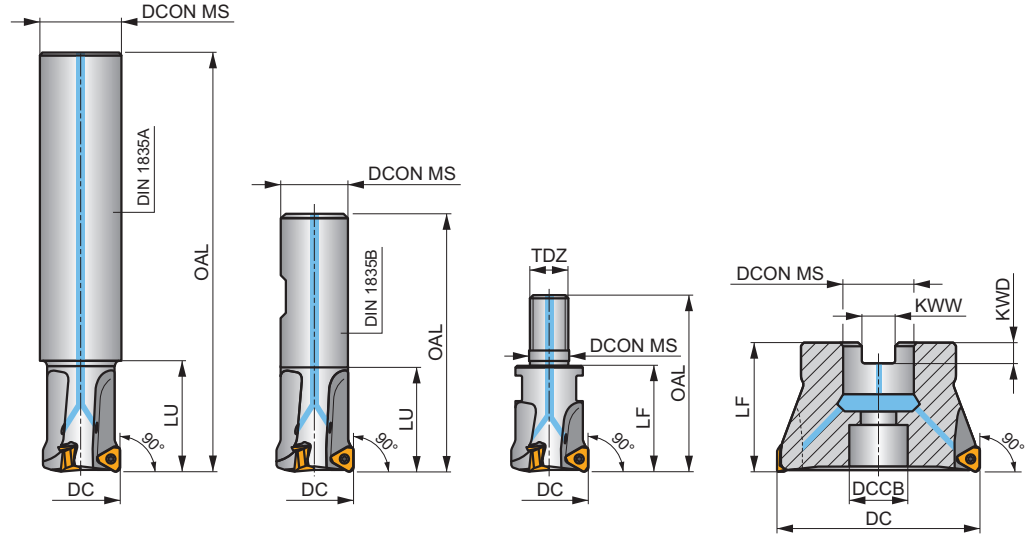
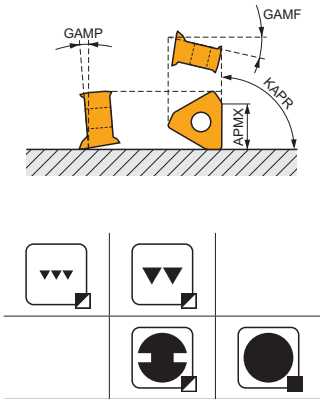

Product	DC (mm)	OAL (mm)	DCON MS (mm)	DCCB (mm)	LU (mm)	LF (mm)	TDZ	KWW (mm)	KWD (mm)	GAMP (°)	GAMP (°)	max.	kg	G1292	SQ300	-	
																	(mm)
18A2R050A20-STN10-C	18	180	20	-	50	-	-	-	-	-17.1	-11	2	-	29100	✓	0.39	GI292 SQ300 -
20A2R029A20-STN10-C	20	150	20	-	29	-	-	-	-	-16.5	-11	2	-	27600	✓	0.35	GI292 SQ300 -
20A3R029A20-STN10-C	20	150	20	-	29	-	-	-	-	-16.5	-11	3	-	27600	✓	0.34	GI292 SQ300 -
22A3R050A25-STN10-C	22	180	25	-	50	-	-	-	-	-16.5	-11	3	-	26300	✓	0.58	GI292 SQ300 -
25A3R034A25-STN10-C	25	170	25	-	34	-	-	-	-	-16	-11	3	-	24700	✓	0.58	GI292 SQ300 -
25A4R034A25-STN10-C	25	170	25	-	34	-	-	-	-	-16	-11	4	✓	24700	✓	0.58	GI292 SQ300 -
30A4R050A32-STN10-C	30	200	32	-	50	-	-	-	-	-16	-11	4	✓	22500	✓	1.06	GI292 SQ300 -
32A4R037A32-STN10-C	32	195	32	-	37	-	-	-	-	-16	-11	4	✓	21800	✓	1.08	GI292 SQ300 -
32A5R037A32-STN10-C	32	195	32	-	37	-	-	-	-	-16	-11	5	✓	21800	✓	1.08	GI292 SQ300 -
35A5R080A32-STN10-C	35	200	32	-	80	-	-	-	-	-16	-11	5	✓	20800	✓	1.07	GI292 SQ300 -
20A2R032B20-STN10-C	20	90	20	-	32	-	-	-	-	-16.5	-11	2	-	27600	✓	0.20	GI292 SQ300 -
20A3R032B20-STN10-C	20	90	20	-	32	-	-	-	-	-16.5	-11	3	-	27600	✓	0.19	GI292 SQ300 -
25A3R042B25-STN10-C	25	100	25	-	42	-	-	-	-	-16	-11	3	-	24700	✓	0.31	GI292 SQ300 -
25A4R042B25-STN10-C	25	100	25	-	42	-	-	-	-	-16	-11	4	✓	24700	✓	0.31	GI292 SQ300 -
32A4R042B32-STN10-C	32	110	32	-	42	-	-	-	-	-16	-11	4	✓	21800	✓	0.57	GI292 SQ300 -
32A5R042B32-STN10-C	32	110	32	-	42	-	-	-	-	-16	-11	5	✓	21800	✓	0.56	GI292 SQ300 -
20A2R026M10-STN10-C	20	45	10.5	-	-	26	M10	-	-	-16.5	-11	2	-	✓	0.06	GI292 SQ300 -	
20A3R026M10-STN10-C	20	45	10.5	-	-	26	M10	-	-	-16.5	-11	3	-	✓	0.06	GI292 SQ300 -	
25A3R033M12-STN10-C	25	55	12.5	-	-	33	M12	-	-	-16	-11	3	-	✓	0.10	GI292 SQ300 -	
25A4R033M12-STN10-C	25	55	12.5	-	-	33	M12	-	-	-16	-11	4	✓	-	✓	0.10	GI292 SQ300 -
32A4R043M16-STN10-C	32	66	17	-	-	43	M16	-	-	-16	-11	4	✓	-	✓	0.21	GI292 SQ300 -
32A5R043M16-STN10-C	32	66	17	-	-	43	M16	-	-	-16	-11	5	✓	-	✓	0.21	GI292 SQ300 -
40A04R-S90TN10-C	40	-	16	14	-	40	-	8.4	5.6	-15	-11	4	✓	19500	✓	0.34	GI292 SQ302 -
40A06R-S90TN10-C	40	-	16	14	-	40	-	8.4	5.6	-15	-11	6	✓	19500	✓	0.34	GI292 SQ302 -
50A05R-S90TN10-C	50	-	22	18	-	40	-	10.4	6.3	-15	-11	5	✓	17400	✓	0.48	GI292 SQ303 -
50A07R-S90TN10-C	50	-	22	18	-	40	-	10.4	6.3	-15	-11	7	✓	17400	✓	0.49	GI292 SQ303 -
63A06R-S90TN10-C	63	-	22	18	-	40	-	10.4	6.3	-15	-11	6	✓	15500	✓	0.63	GI292 SQ303 -

Product	DC	OAL	D CONIMS	DCB	LU	LF	TDZ	KWW	KWD	GAMF	GAMP	max.		kg	GI292	SQ303	AC001		
	(mm)	(mm)	(mm)	(mm)	(mm)	(mm)	(mm)	(mm)	(mm)	(°)	(°)	15500	13800						
63A09R-S90TN10-C	63	-	22	18	-	40	-	10.4	6.3	-15	-11	9	✓	15500	✓	0.63	GI292	SQ303	-
80A10R-S90TN10-C	80	-	27	38	-	50	-	12.4	7	-15	-11	10	✓	13800	✓	1.03	GI292	SQ301	AC001

	TNGX 1004..
--	-------------

SQ300	US 52506-T07P	0.8	M 2.5	6	-	-	Flag T07P	-
SQ301	US 52506-T07P	0.8	M 2.5	6	D-T07P/T09P	FG-15	-	-
SQ302	US 52506-T07P	0.8	M 2.5	6	D-T07P/T09P	FG-15	-	HS 0830C
SQ303	US 52506-T07P	0.8	M 2.5	6	D-T07P/T09P	FG-15	-	HS 1030C

AC001	KS 1230	K.FMH27
-------	---------	---------

TNGX 10



IC	D1	L	S	
(mm)	(mm)	(mm)	(mm)	
1004	6.000	2.80	10.39	4.69

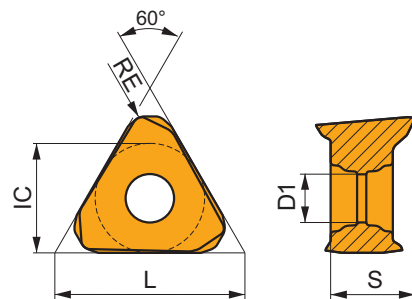

Suitability and starting values for cutting speed (vc), feed (f) and depth of cut (ap). Refer to our Machining Calculator app for further calculations.

Product	RE	P			M			K			N			S			H		
		vc	f	ap	vc	f	ap	vc	f	ap	vc	f	ap	vc	f	ap	vc	f	ap
	(mm)	(m/min)	(mm/tooth)	(mm)	(m/min)	(mm/tooth)	(mm)	(m/min)	(mm/tooth)	(mm)	(m/min)	(mm/tooth)	(mm)	(m/min)	(mm/tooth)	(mm)	(m/min)	(mm/tooth)	(mm)

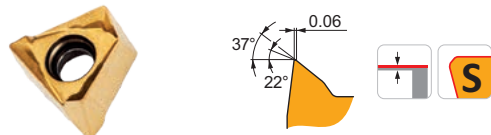

F geometry with highly positive design for light machining.

TNGX 100402SR-F:M8330	●	0.2	205	0.09	2.0	120	0.08	2.0	190	0.09	2.0	-	-	-	-	-	-	-	-
TNGX 100402SR-F:M8340	●	0.2	190	0.09	2.0	110	0.08	2.0	180	0.09	2.0	-	-	-	-	-	-	-	-
TNGX 100404SR-F:8215	●	0.4	225	0.09	2.0	135	0.08	2.0	210	0.09	2.0	-	-	-	-	-	-	-	-
TNGX 100404SR-F:M6330	●	0.4	190	0.09	2.0	135	0.08	2.0	-	-	-	-	-	-	-	-	-	-	-
TNGX 100404SR-F:M8330	●	0.4	220	0.09	2.0	130	0.08	2.0	205	0.09	2.0	-	-	-	-	-	-	-	-
TNGX 100404SR-F:M8340	●	0.4	200	0.09	2.0	120	0.08	2.0	190	0.09	2.0	-	-	-	-	-	-	-	-
TNGX 100404SR-F:M9340	●	0.4	270	0.09	2.0	160	0.08	2.0	-	-	-	-	-	-	-	-	-	-	-
TNGX 100408SR-F:8215	●	0.8	270	0.09	2.0	160	0.08	2.0	255	0.09	2.0	-	-	-	-	-	-	-	-
TNGX 100408SR-F:M6330	●	0.8	225	0.09	2.0	160	0.08	2.0	-	-	-	-	-	-	-	-	-	-	-
TNGX 100408SR-F:M8330	●	0.8	260	0.09	2.0	155	0.08	2.0	245	0.09	2.0	-	-	-	-	-	-	-	-
TNGX 100408SR-F:M8340	●	0.8	240	0.09	2.0	140	0.08	2.0	225	0.09	2.0	-	-	-	-	-	-	-	-
TNGX 100408SR-F:M9340	●	0.8	320	0.09	2.0	190	0.08	2.0	-	-	-	-	-	-	-	-	-	-	-

Suitability and starting values for cutting speed (vc), feed (f) and depth of cut (ap). Refer to our Machining Calculator app for further calculations.

Product	RE (mm)	P			M			K			N			S			H		
		vc (m/min)	f (mm/tooth)	ap (mm)	vc (m/min)	f (mm/tooth)	ap (mm)	vc (m/min)	f (mm/tooth)	ap (mm)	vc (m/min)	f (mm/tooth)	ap (mm)	vc (m/min)	f (mm/tooth)	ap (mm)	vc (m/min)	f (mm/tooth)	ap (mm)

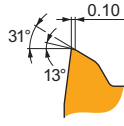
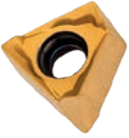

M geometry with positive design for light to medium machining.

TNGX 100404SR-M:8215	● 0.4	■ 205	■ 0.13	■ 2.0	■ 120	■ 0.12	■ 2.0	■ 190	■ 0.13	■ 2.0	■ —	■ —	■ —	■ 50	■ 0.09	■ 1.6	■ —	■ —	■ —
TNGX 100404SR-M:M6330	● 0.4	■ 175	■ 0.13	■ 2.0	■ 125	■ 0.12	■ 2.0	■ —	■ —	■ —	■ —	■ —	■ —	■ 50	■ 0.09	■ 1.6	■ —	■ —	■ —
TNGX 100404SR-M:M8330	● 0.4	■ 205	■ 0.13	■ 2.0	■ 120	■ 0.12	■ 2.0	■ 190	■ 0.13	■ 2.0	■ —	■ —	■ —	■ 50	■ 0.09	■ 1.6	■ —	■ —	■ —
TNGX 100404SR-M:M8340	● 0.4	■ 185	■ 0.13	■ 2.0	■ 110	■ 0.12	■ 2.0	■ 175	■ 0.13	■ 2.0	■ —	■ —	■ —	■ 45	■ 0.09	■ 1.6	■ —	■ —	■ —
TNGX 100404SR-M:M9340	● 0.4	■ 240	■ 0.13	■ 2.0	■ 140	■ 0.12	■ 2.0	■ —	■ —	■ —	■ —	■ —	■ —	■ 60	■ 0.09	■ 1.6	■ —	■ —	■ —
TNGX 100408SR-M:8215	● 0.8	■ 245	■ 0.13	■ 2.0	■ 145	■ 0.12	■ 2.0	■ 230	■ 0.13	■ 2.0	■ —	■ —	■ —	■ 60	■ 0.09	■ 1.6	■ —	■ —	■ —
TNGX 100408SR-M:M6330	● 0.8	■ 210	■ 0.13	■ 2.0	■ 150	■ 0.12	■ 2.0	■ —	■ —	■ —	■ —	■ —	■ —	■ 60	■ 0.09	■ 1.6	■ —	■ —	■ —
TNGX 100408SR-M:M8310	● 0.8	■ 270	■ 0.13	■ 2.0	■ 135	■ 0.12	■ 2.0	■ 255	■ 0.13	■ 2.0	■ —	■ —	■ —	■ —	■ —	■ —	■ —	■ —	■ —
TNGX 100408SR-M:M8330	● 0.8	■ 245	■ 0.13	■ 2.0	■ 145	■ 0.12	■ 2.0	■ 230	■ 0.13	■ 2.0	■ —	■ —	■ —	■ 60	■ 0.09	■ 1.6	■ —	■ —	■ —
TNGX 100408SR-M:M8340	● 0.8	■ 220	■ 0.13	■ 2.0	■ 130	■ 0.12	■ 2.0	■ 205	■ 0.13	■ 2.0	■ —	■ —	■ —	■ 55	■ 0.09	■ 1.6	■ —	■ —	■ —
TNGX 100408SR-M:M8345	● 0.8	■ 180	■ 0.13	■ 2.0	■ 105	■ 0.12	■ 2.0	■ —	■ —	■ —	■ —	■ —	■ —	■ 45	■ 0.09	■ 1.6	■ —	■ —	■ —
TNGX 100408SR-M:M9340	● 0.8	■ 285	■ 0.13	■ 2.0	■ 170	■ 0.12	■ 2.0	■ —	■ —	■ —	■ —	■ —	■ —	■ 70	■ 0.09	■ 1.6	■ —	■ —	■ —
TNGX 100412SR-M:M8330	● 1.2	■ 255	■ 0.13	■ 2.0	■ 150	■ 0.12	■ 2.0	■ 240	■ 0.13	■ 2.0	■ —	■ —	■ —	■ 60	■ 0.09	■ 1.6	■ —	■ —	■ —
TNGX 100412SR-M:M8340	● 1.2	■ 230	■ 0.13	■ 2.0	■ 135	■ 0.12	■ 2.0	■ 215	■ 0.13	■ 2.0	■ —	■ —	■ —	■ 55	■ 0.09	■ 1.6	■ —	■ —	■ —
TNGX 100416SR-M:M8310	● 1.6	■ 300	■ 0.13	■ 2.0	■ 150	■ 0.12	■ 2.0	■ 285	■ 0.13	■ 2.0	■ —	■ —	■ —	■ —	■ —	■ —	■ —	■ —	■ —
TNGX 100416SR-M:M8330	● 1.6	■ 270	■ 0.13	■ 2.0	■ 160	■ 0.12	■ 2.0	■ 255	■ 0.13	■ 2.0	■ —	■ —	■ —	■ 65	■ 0.09	■ 1.6	■ —	■ —	■ —
TNGX 100416SR-M:M8340	● 1.6	■ 245	■ 0.13	■ 2.0	■ 145	■ 0.12	■ 2.0	■ 230	■ 0.13	■ 2.0	■ —	■ —	■ —	■ 60	■ 0.09	■ 1.6	■ —	■ —	■ —

TNGX 10-FA



	IC (mm)	D1 (mm)	L (mm)	S (mm)
1004	6.000	2.80	10.39	4.69

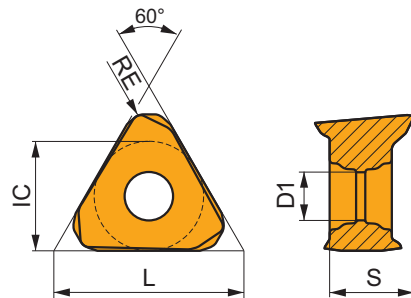

Suitability and starting values for cutting speed (vc), feed (f) and depth of cut (ap). Refer to our Machining Calculator app for further calculations.

Product	RE (mm)	P			M			K			N			S			H		
		vc (m/min)	f (mm/tooth)	ap (mm)	vc (m/min)	f (mm/tooth)	ap (mm)	vc (m/min)	f (mm/tooth)	ap (mm)	vc (m/min)	f (mm/tooth)	ap (mm)	vc (m/min)	f (mm/tooth)	ap (mm)	vc (m/min)	f (mm/tooth)	ap (mm)

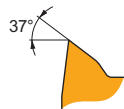
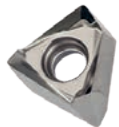

FA geometry with highly positive design for fine-finish to medium machining.

TNGX 100404FR-FA:HF7	● 0.4	■ —	■ —	■ —	■ —	■ —	■ —	■ —	■ —	■ —	■ 345	■ 0.10	■ 1.5	■ —	■ —	■ —	■ —	■ —	■ —
TNGX 100404FR-FA:M0315	● 0.4	■ —	■ —	■ —	■ —	■ —	■ —	■ —	■ —	■ —	■ 780	■ 0.10	■ 1.5	■ —	■ —	■ —	■ —	■ —	■ —
TNGX 100408FR-FA:HF7	● 0.8	■ —	■ —	■ —	■ —	■ —	■ —	■ —	■ —	■ —	■ 345	■ 0.10	■ 1.5	■ —	■ —	■ —	■ —	■ —	■ —
TNGX 100408FR-FA:M0315	● 0.8	■ —	■ —	■ —	■ —	■ —	■ —	■ —	■ —	■ —	■ 780	■ 0.10	■ 1.5	■ —	■ —	■ —	■ —	■ —	■ —



a_e / DC	5%	10%	15%	20%	25%	30%	40%	50%	60%	70%	75%	80%	90%	100%
	1.48	1.35	1.27	1.22	1.19	1.16	1.11	1.08	1.05	1.03	1.00	1.00	1.00	1.00
	2.20	1.60	1.35	1.20	1.10	0.95	0.85	0.75	0.85	0.95	1.00	1.00	1.00	1.00
	0.64	0.64	0.64	0.64	0.64	0.65	0.65	0.67	0.68	0.71	0.72	0.74	0.79	1.00

	TNGX 10-F			TNGX 10-M				TNGX 10-FA	
	0.2	0.4	0.8	0.4	0.8	1.2	1.6	0.4	0.8
	1.53	1.34	0.92	1.34	0.92			1.33	0.93

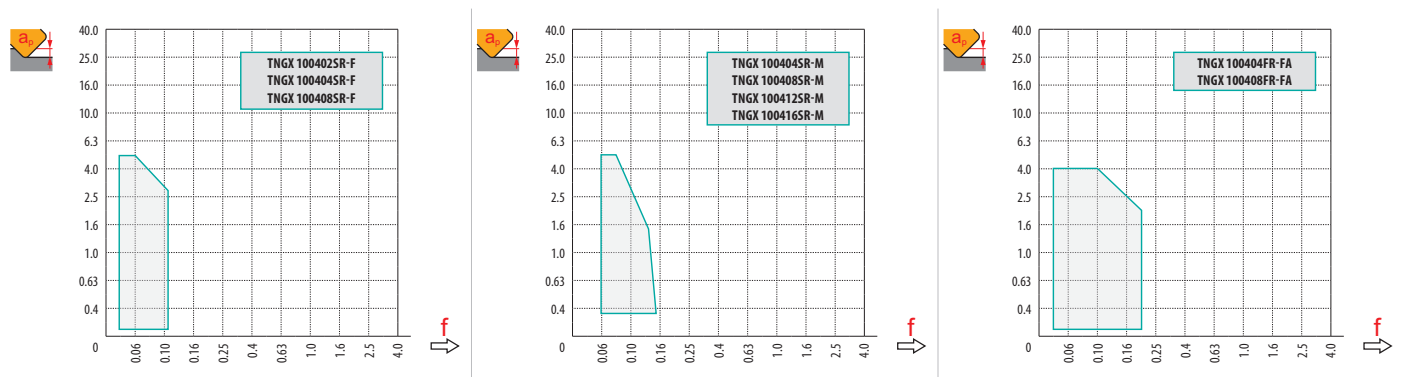

1.5	1.0 3.0 5.0	0.2
	0.10 0.08 0.04	

	RPMX	APMX/l		DMIN	DMAX		
						DMIN	DMAX
18	1.80°	3.05/100	18	33	36	1.2	1.2
20	1.60°	2.70/100	20	37	40	1.2	1.2
22	1.20°	2.00/100	22	41	44	1.0	1.0
25	1.00°	1.70/100	25	47	50	1.0	1.0
30	0.90°	1.45/100	30	57	60	1.0	1.0
32	0.80°	1.30/100	32	61	64	1.0	1.0
35	0.65°	1.00/100	35	67	70	0.9	0.9
40	0.60°	0.90/100	40	77	80	0.9	0.9
50	0.50°	0.70/100	50	97	100	0.9	0.9
63	0.40°	0.50/100	63	123	126	0.9	0.9
80	0.25°	0.30/100	80	157	160	0.9	0.9

STN16



PRAMET

S



ECON TN16 Square Shoulder Mill with Internal Coolant

90° end and shell mills utilizing double sided TNGX 16 inserts with 6 cutting edges and APMX of 10 mm. Suitable for a wide range of applications. Available in cylindrical, Weldon, modular and arbor (with differential tooth pitch) style. Body treated for longer tool life.

ECON TN

KAPR	90°
APMX	10.0 mm

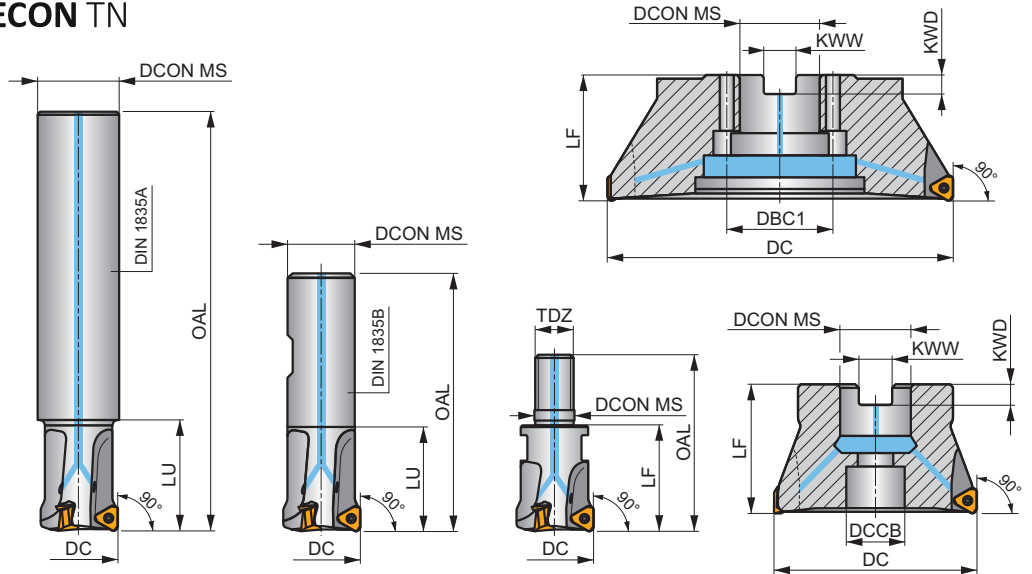
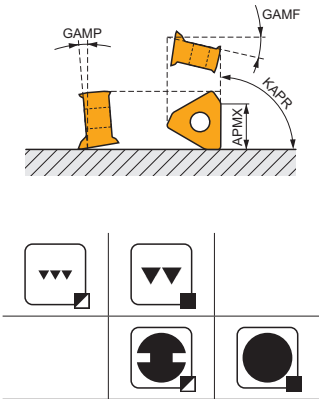

	0.03 - 0.13				
	0.03 - 0.15				

Product	DC (mm)	OAL (mm)	DCON MS (mm)	DCCB (mm)	DBC1 (mm)	LU (mm)	LF (mm)	TDZ (mm)	KWW (mm)	KWD (mm)	GAMP (°)	GAMP (°)							
																	max.	kg	Material
25A2R034A25-STN16-C	25	170	25	-	-	34	-	-	-	-	-18.5	-9.5	2	-	20000	✓	0.54	GI340	C0382
32A2R034A32-STN16-C	32	195	32	-	-	34	-	-	-	-	-16	-9.5	2	-	17500	✓	1.05	GI340	C0382
25A2R080A25-STN16-C	25	170	25	-	-	80	-	-	-	-	-18.5	-9.5	2	-	20000	✓	0.48	GI340	C0382
32A2R080A32-STN16-C	32	195	32	-	-	80	-	-	-	-	-16	-9.5	2	-	17500	✓	0.96	GI340	C0382
32A3R034A32-STN16-C	32	195	32	-	-	34	-	-	-	-	-16	-9.5	3	-	17500	✓	1.04	GI340	C0382
35A3R034A32-STN16-C	35	195	32	-	-	34	-	-	-	-	-16	-9.5	3	-	17000	✓	1.07	GI340	C0382
25A2R042B25-STN16-C	25	110	25	-	-	42	-	-	-	-	-18.5	-9.5	2	-	20000	✓	0.29	GI340	C0382
32A3R042B32-STN16-C	32	110	32	-	-	42	-	-	-	-	-16	-9.5	3	-	17500	✓	0.52	GI340	C0382
40A4R050B32-STN16-C	40	120	32	-	-	50	-	-	-	-	-16	-9.5	4	-	16000	✓	0.68	GI340	C0382
25A2R033M12-STN16-C	25	55	12.5	-	-	-	33	M12	-	-	-18.5	-9.5	2	-	20000	✓	0.10	GI340	C0382
32A2R043M16-STN16-C	32	66	17	-	-	-	43	M16	-	-	-16	-9.5	2	-	17500	✓	0.18	GI340	C0382
32A3R043M16-STN16-C	32	66	17	-	-	-	43	M16	-	-	-16	-9.5	3	-	17500	✓	0.17	GI340	C0382
40A3R043M16-STN16-C	40	66	17	-	-	-	43	M16	-	-	-16	-9.5	3	-	16000	✓	0.20	GI340	C0382
40A4R043M16-STN16-C	40	66	17	-	-	-	43	M16	-	-	-16	-9.5	4	-	16000	✓	0.21	GI340	C0382
40A03R-S90TN16-C	40	40	16	12.4	-	-	40	-	8.4	5.6	-16	-9.5	3	-	16000	✓	0.32	GI340	C0384
40A04R-S90TN16-C	40	40	16	12.4	-	-	40	-	8.4	5.6	-16	-9.5	4	-	16000	✓	0.31	GI340	C0384
50A04R-S90TN16-C	50	40	22	18.1	-	-	40	-	10.4	6.3	-16	-9.5	4	✓	14000	✓	0.34	GI340	C0386
50A05R-S90TN16-C	50	40	22	18.1	-	-	40	-	10.4	6.3	-16	-9.5	5	✓	14000	✓	0.32	GI340	C0386
63A04R-S90TN16-C	63	40	22	18.1	-	-	40	-	10.4	6.3	-16	-9.5	4	✓	12500	✓	0.47	GI340	C0386
63A06R-S90TN16-C	63	40	22	18.1	-	-	40	-	10.4	6.3	-16	-9.5	6	✓	12500	✓	0.48	GI340	C0386
80A05R-S90TN16-C	80	50	27	22.1	-	-	50	-	12.4	7	-16	-9.5	5	✓	11000	✓	1.15	GI340	C0388
80A07R-S90TN16-C	80	50	27	22.1	-	-	50	-	12.4	7	-16	-9.5	7	✓	11000	✓	1.17	GI340	C0388
100A06R-S90TN16-C	100	50	32	45.1	-	-	50	-	14.4	8	-16	-9.5	6	✓	10000	✓	1.79	GI340	C0390
100A08R-S90TN16-C	100	50	32	45.1	-	-	50	-	14.4	8	-16	-9.5	8	✓	10000	✓	1.66	GI340	C0390
115A06R-S90TN16-C	115	50	32	45.1	-	-	50	-	14.4	8	-16	-9.5	6	✓	9500	✓	2.21	GI340	C0390
125A07R-S90TN16-C	125	63	40	56.1	-	-	63	-	16.4	9	-16	-9.5	7	✓	9000	✓	3.05	GI340	C0390
125A09R-S90TN16-C	125	63	40	56.1	-	-	63	-	16.4	9	-16	-9.5	9	✓	9000	✓	3.14	GI340	C0390

Product	DC	OAL	D CONIMS	DCB	DBC1	LU	LF	TDZ	KWW	KWD	GAMF	GAMP	max.			kg		
	(mm)	(mm)	(mm)	(mm)	(mm)	(mm)	(mm)	(mm)	(mm)	(mm)	(°)	(°)						
140A08R-S90TN16-C	140	63	40	56.1	-	-	63	-	16.4	9	-16	-9.5	8	✓	8500	✓	3.69	GI340 C0390
160C10R-S90TN16-C	160	63	40	-	66.7	-	63	-	16.4	9.2	-16	-9.5	10	✓	8000	✓	5.16	GI340 C0394
175C10R-S90TN16-C	175	63	40	-	66.7	-	63	-	16.4	9.2	-16	-9.5	10	✓	7500	✓	6.89	GI340 C0394

	GI340		TNGX 1606..
--	-------	--	-------------

C0382	US 44010-T15P	3.5	M 4	10	-	-	Flag T15P	-	-	-	-
C0384	US 44010-T15P	3.5	M 4	10	D-T08P/T15P	FG-15	-	HS 90835	-	-	-
C0386	US 44010-T15P	3.5	M 4	10	D-T08P/T15P	FG-15	-	HS 1030C	-	-	-
C0388	US 44010-T15P	3.5	M 4	10	D-T08P/T15P	FG-15	-	HS 1230C	-	-	-
C0390	US 44010-T15P	3.5	M 4	10	D-T08P/T15P	FG-15	-	-	-	-	-
C0394	US 44010-T15P	3.5	M 4	10	D-T08P/T15P	FG-15	-	HS 1240C	HSD 0825C	CAC 160C	-

TNGX 16



	IC	D1	L	S
	(mm)	(mm)	(mm)	(mm)
1606	9.525	4.40	16.50	6.58

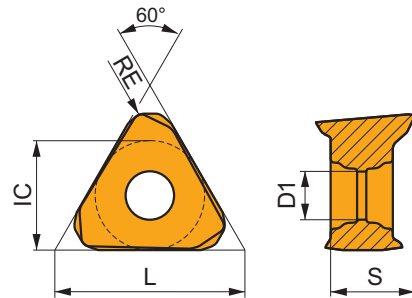

Suitability and starting values for cutting speed (vc), feed (f) and depth of cut (ap). Refer to our Machining Calculator app for further calculations.

Product	RE (mm)	P			M			K			N			S			H		
		vc	f	ap	vc	f	ap	vc	f	ap	vc	f	ap	vc	f	ap	vc	f	ap
		(m/min)	(mm/tooth)	(mm)	(m/min)	(mm/tooth)	(mm)	(m/min)	(mm/tooth)	(mm)	(m/min)	(mm/tooth)	(mm)	(m/min)	(mm/tooth)	(mm)	(m/min)	(mm/tooth)	(mm)

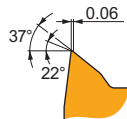
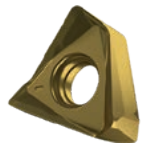

F geometry with highly positive design for light machining.

TNGX 160604SR-F:M8330	● 0.4	■ 205	■ 0.10	■ 3.0	■ 120	■ 0.09	■ 3.0	■ 190	■ 0.10	■ 3.0	-	-	-	-	-	-	-	-	-
TNGX 160604SR-F:M8340	● 0.4	■ 190	■ 0.10	■ 3.0	■ 110	■ 0.09	■ 3.0	■ 180	■ 0.10	■ 3.0	-	-	-	-	-	-	-	-	-
TNGX 160608SR-F:8215	● 0.8	■ 250	■ 0.10	■ 3.0	■ 150	■ 0.09	■ 3.0	■ 235	■ 0.10	■ 3.0	-	-	-	-	-	-	-	-	-
TNGX 160608SR-F:M6330	● 0.8	■ 215	■ 0.10	■ 3.0	■ 150	■ 0.09	■ 3.0	-	-	-	-	-	-	-	-	-	-	-	-
TNGX 160608SR-F:M8310	● 0.8	■ 280	■ 0.10	■ 3.0	■ 140	■ 0.09	■ 3.0	■ 265	■ 0.10	■ 3.0	-	-	-	-	-	-	-	-	-
TNGX 160608SR-F:M8330	● 0.8	■ 245	■ 0.10	■ 3.0	■ 145	■ 0.09	■ 3.0	■ 230	■ 0.10	■ 3.0	-	-	-	-	-	-	-	-	-
TNGX 160608SR-F:M8340	● 0.8	■ 225	■ 0.10	■ 3.0	■ 135	■ 0.09	■ 3.0	■ 210	■ 0.10	■ 3.0	-	-	-	-	-	-	-	-	-

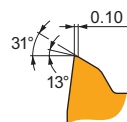
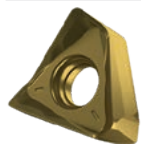

M geometry with positive design for light to medium machining.

TNGX 160604SR-M:8215	● 0.4	■ 180	■ 0.18	■ 3.0	■ 105	■ 0.16	■ 3.0	■ 170	■ 0.18	■ 3.0	-	-	-	■ 45	■ 0.13	■ 2.4	-	-	-
TNGX 160604SR-M:M6330	● 0.4	■ 155	■ 0.18	■ 3.0	■ 110	■ 0.16	■ 3.0	-	-	-	-	-	-	■ 45	■ 0.13	■ 2.4	-	-	-
TNGX 160604SR-M:M8310	● 0.4	■ 205	■ 0.15	■ 3.0	■ 100	■ 0.14	■ 3.0	■ 190	■ 0.15	■ 3.0	-	-	-	-	-	-	-	-	-
TNGX 160604SR-M:M8330	● 0.4	■ 180	■ 0.18	■ 3.0	■ 105	■ 0.16	■ 3.0	■ 170	■ 0.18	■ 3.0	-	-	-	■ 45	■ 0.13	■ 2.4	-	-	-

Suitability and starting values for cutting speed (vc), feed (f) and depth of cut (ap). Refer to our Machining Calculator app for further calculations.

Product	RE (mm)	P			M			K			N			S			H		
		vc (m/min)	f (mm/tooth)	ap (mm)	vc (m/min)	f (mm/tooth)	ap (mm)	vc (m/min)	f (mm/tooth)	ap (mm)	vc (m/min)	f (mm/tooth)	ap (mm)	vc (m/min)	f (mm/tooth)	ap (mm)	vc (m/min)	f (mm/tooth)	ap (mm)

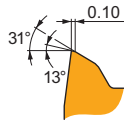
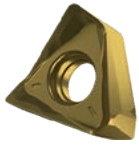

M geometry with positive design for light to medium machining.

TNGX 160604SR-M:M8340	● 0.4	165	0.18	3.0	95	0.16	3.0	155	0.18	3.0	—	—	—	40	0.13	2.4	—	—	—
TNGX 160608SR-M:8215	● 0.8	215	0.18	3.0	125	0.16	3.0	200	0.18	3.0	—	—	—	50	0.13	2.4	—	—	—
TNGX 160608SR-M:M6330	● 0.8	185	0.18	3.0	130	0.16	3.0	—	—	—	—	—	—	55	0.13	2.4	—	—	—
TNGX 160608SR-M:M8310	● 0.8	245	0.15	3.0	120	0.14	3.0	230	0.15	3.0	—	—	—	—	—	—	—	—	—
TNGX 160608SR-M:M8330	● 0.8	215	0.18	3.0	125	0.16	3.0	200	0.18	3.0	—	—	—	50	0.13	2.4	—	—	—
TNGX 160608SR-M:M8340	● 0.8	195	0.18	3.0	115	0.16	3.0	185	0.18	3.0	—	—	—	45	0.13	2.4	—	—	—
TNGX 160608SR-M:M8345	● 0.8	155	0.18	3.0	90	0.16	3.0	—	—	—	—	—	—	35	0.13	2.4	—	—	—
TNGX 160608SR-M:M9325	● 0.8	285	0.15	3.0	—	—	—	270	0.15	3.0	—	—	—	—	—	—	—	—	—
TNGX 160608SR-M:M9340	● 0.8	245	0.18	3.0	145	0.16	3.0	—	—	—	—	—	—	60	0.13	2.4	—	—	—
TNGX 160612SR-M:M8330	● 1.2	230	0.18	3.0	135	0.16	3.0	215	0.18	3.0	—	—	—	55	0.13	2.4	—	—	—
TNGX 160612SR-M:M8340	● 1.2	205	0.18	3.0	120	0.16	3.0	190	0.18	3.0	—	—	—	50	0.13	2.4	—	—	—
TNGX 160616SR-M:M8310	● 1.6	275	0.15	3.0	140	0.14	3.0	260	0.15	3.0	—	—	—	—	—	—	—	—	—
TNGX 160616SR-M:M8330	● 1.6	240	0.18	3.0	140	0.16	3.0	225	0.18	3.0	—	—	—	60	0.13	2.4	—	—	—
TNGX 160616SR-M:M8340	● 1.6	220	0.18	3.0	130	0.16	3.0	205	0.18	3.0	—	—	—	55	0.13	2.4	—	—	—

TNGX 16-FA



	IC (mm)	D1 (mm)	L (mm)	S (mm)
1606	9.525	4.40	16.50	6.58

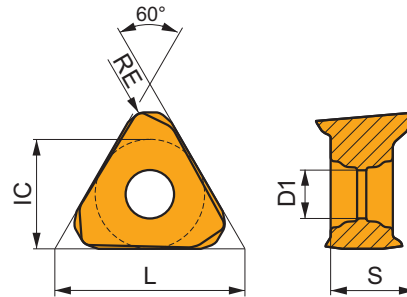

Suitability and starting values for cutting speed (vc), feed (f) and depth of cut (ap). Refer to our Machining Calculator app for further calculations.

Product	RE (mm)	P			M			K			N			S			H		
		vc (m/min)	f (mm/tooth)	ap (mm)	vc (m/min)	f (mm/tooth)	ap (mm)	vc (m/min)	f (mm/tooth)	ap (mm)	vc (m/min)	f (mm/tooth)	ap (mm)	vc (m/min)	f (mm/tooth)	ap (mm)	vc (m/min)	f (mm/tooth)	ap (mm)

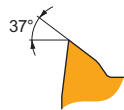
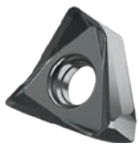

FA geometry with highly positive design for fine-finish to medium machining.

TNGX 160604FR-FA:HF7	● 0.4	—	—	—	—	—	—	—	—	—	255	0.14	2.0	—	—	—	—	—	—
TNGX 160604FR-FA:M0315	● 0.4	—	—	—	—	—	—	—	—	—	585	0.14	2.0	—	—	—	—	—	—
TNGX 160608FR-FA:HF7	● 0.8	—	—	—	—	—	—	—	—	—	300	0.14	2.0	—	—	—	—	—	—
TNGX 160608FR-FA:M0315	● 0.8	—	—	—	—	—	—	—	—	—	690	0.14	2.0	—	—	—	—	—	—



a_e / DC	5 %	10 %	15 %	20 %	25 %	30 %	40 %	50 %	60 %	70 %	75 %	80 %	90 %	100 %
	1.48	1.35	1.27	1.22	1.19	1.16	1.11	1.08	1.05	1.03	1.00	1.00	1.00	1.00
	2.20	1.60	1.35	1.20	1.10	0.95	0.85	0.75	0.85	0.95	1.00	1.00	1.00	1.00
	0.64	0.64	0.64	0.64	0.64	0.65	0.65	0.67	0.68	0.71	0.72	0.74	0.79	1.00

	TNGX 16-F		TNGX 16-M				TNGX 16-FA	
	0.4	0.8	0.4	0.8	1.2	1.6	0.4	0.8
	2.10	1.9	2.10	1.90	1.73	1.14	2.10	1.90

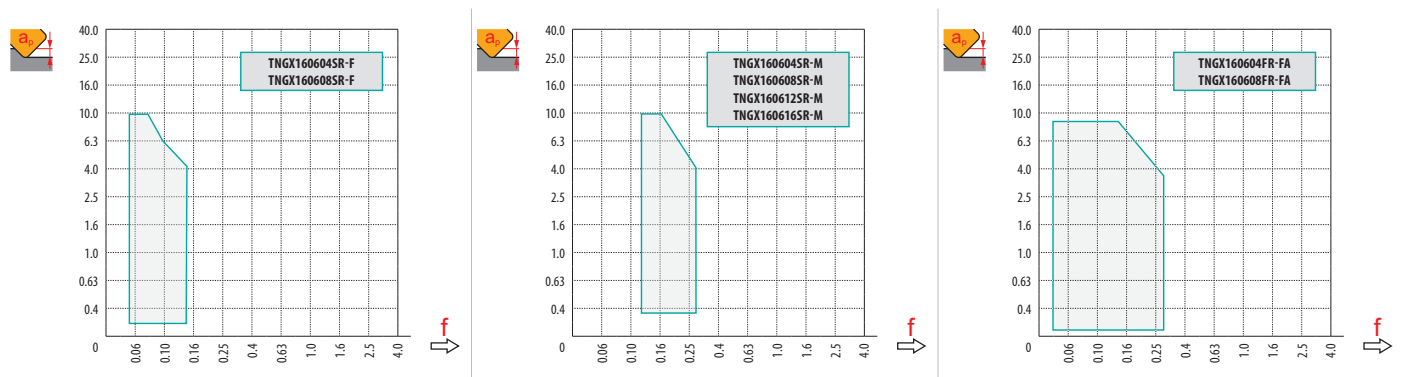

a	3.0	4.5	6.0
	0.18	0.14	0.10



DC	min	$d_{min} = DC^*$		min	$d = 1.25 DC$		min	$d = 1.5 DC$		min	$d = 1.75 DC$		min	$d \geq 2 DC$	
		SMAX	$a_{e max}$		SMAX	$a_{e max}$		SMAX	$a_{e max}$		SMAX	$a_{e max}$		SMAX	$a_{e max}$
25	25	0.14	1.3	31	0.22	2.2	38	0.33	3.0	44	0.60	4.0	50	0.70	5.0
32	32	0.16	1.5	40	0.33	2.8	48	0.44	4.0	56	0.70	5.0	64	0.90	6.5
40	40	0.22	2.0	50	0.38	3.5	60	0.55	5.0	70	0.90	6.5	80	1.15	8.0
50	50	0.27	2.5	63	0.50	4.5	75	0.70	6.5	88	1.00	8.0	100	1.40	10.0
63	63	0.33	3.2	80	0.60	5.5	95	0.90	8.0	110	1.45	10.0	125	1.80	12.5
80	80	0.55	4.0	100	1.00	7.0	120	1.45	10.0	140	2.15	13.0	160	2.60	16.0
100	100	0.70	5.0	125	1.20	9.0	150	1.80	12.5	175	2.70	16.5	200	3.30	20.0
115	115	0.85	6.0	145	1.50	10.0	175	1.90	14.5	200	2.80	19.0	230	3.80	23.0
125	125	0.90	6.5	155	1.60	11.0	190	2.30	15.5	220	3.10	20.0	250	4.10	25.0
140	140	1.00	7.0	175	1.80	12.5	210	2.60	17.5	245	3.70	23.0	280	4.60	28.0
160	160	1.20	8.0	200	2.00	14.0	240	2.90	20.0	280	4.30	26.0	320	5.30	32.0
175	175	1.30	8.8	220	2.20	15.5	265	3.20	22.0	305	4.70	29.0	350	5.80	35.0

* Check feed rate reduction when hole diameter is between $d_{min} - 1.5 DC$.

